

KHP Limited stage LBCL front-line pathway

Exclude: PMBL, PCNSL, PTL, IVL, leg-type

Case-by-case: primary breast, gastric, bone

Stage I/II
No bulk (7.5cm)

SOC

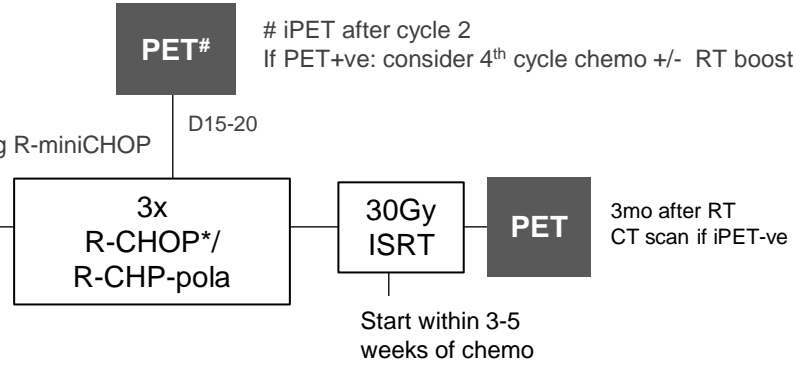

Aim to avoid RT
-Individual risk/benefit**

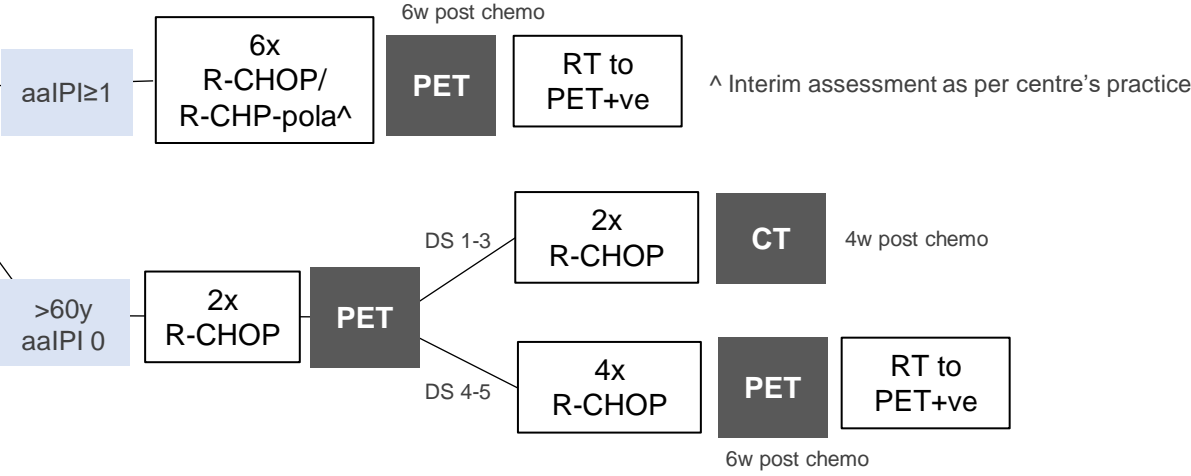

****Consider:**

- Age, comorbidities
- Location, target volume
- Toxicity of chemo (eg cardiac)
- Concern of sec. malign.
- Patient preference

If tumour size/MDT ≥ 5cm: RT usually preferred

aaIPI factors:
ECOG PS >1
eLDH

≤60y
aaIPI 0

FLYER

